

# Chapter 4

---

## Dish Antenna Installation

The dish antenna normally installed for this receiver is a SuperDISH antenna which provides the most expansive high definition programming offering from DISH Network. The SuperDISH installation must be completed by a qualified professional technician due to the complexity of the installation and compliance with national/local building and electrical codes. There may be exceptions where a DISH 500 antenna may be required - consult DISH Network or a DISH Network retailer for the appropriate antenna installation for your system and for professional installation services. The instructions below are provided in the event a DISH 500 antenna is an appropriate installation and uses DISH Pro components identified by the logo shown below.



### Installing a DISH 500 Antenna

---

The first step in installing your dish antenna is to assemble the satellite dish, mount it, and point it in the general direction of a satellite. To do this, follow these instructions:

#### Finding the Satellites

You need to find the satellites in the sky. To do this, you need to know the azimuth angle (the south, southeast, or southwest direction to the satellites) and the elevation angle (the angle up to the satellites) from your location, and the skew angle. Do the following to get these angles:

1. Make sure that the remote control batteries are fresh, and are installed properly. If needed, make sure that the remote is in **SAT** mode to control the satellite receiver.
2. Turn **ON** the television and receiver.

## Dish Antenna Installation

3. Display the **Point Dish** menu, by pressing **MENU** on the Remote and then selecting **System Setup** and then **Point Dish**, or by pressing **MENU-6-2** on the remote (unless the receiver already displays this menu).

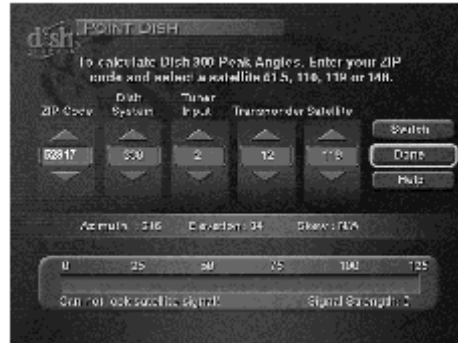

4. Enter your ZIP code in the **ZIP Code** field.
5. The menu displays the azimuth, elevation, and skew angles as shown in the picture. Write down these numbers in the margin.

## Mounting the Dish

1. Using these azimuth and elevation angles, find a location for the satellite dish which can be pointed towards the satellites located at these angles. With a compass, find the required azimuth angle. Then, use the elevation angle to find out how high the satellites are in the sky from your location.

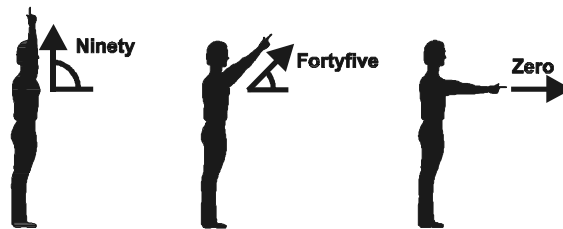

*Make sure nothing blocks the line of sight to the satellites.*

2. Make sure nothing blocks the line of sight to the satellites. Mount the mast to a solid surface so that the dish antenna cannot move or be bumped out of adjustment. Keep in mind that physical and environmental conditions can block your satellite dish's ability to receive a clear satellite signal. Make sure you mount the dish so there are no obstacles between the dish and the satellite. This will help keep the signal strength strong even in bad weather. Obstacles that can block the signal include eaves and overhangs on your building or house, wind, plant growth, and deterioration of the mounting surface. Never mount to a tree.

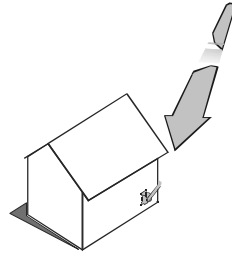

3. Align the top part of the mast so that it is absolutely vertical, as shown below. If the top part of the mast is off vertical by only a few degrees, it will be difficult or maybe even impossible for you to find the satellites.

Take at least two readings with a bubble level, on the upper mast, that are 90 degrees apart from one another.

4. Assemble the satellite dish as shown below, except do not assemble the LNB and Y-bracket at this time.

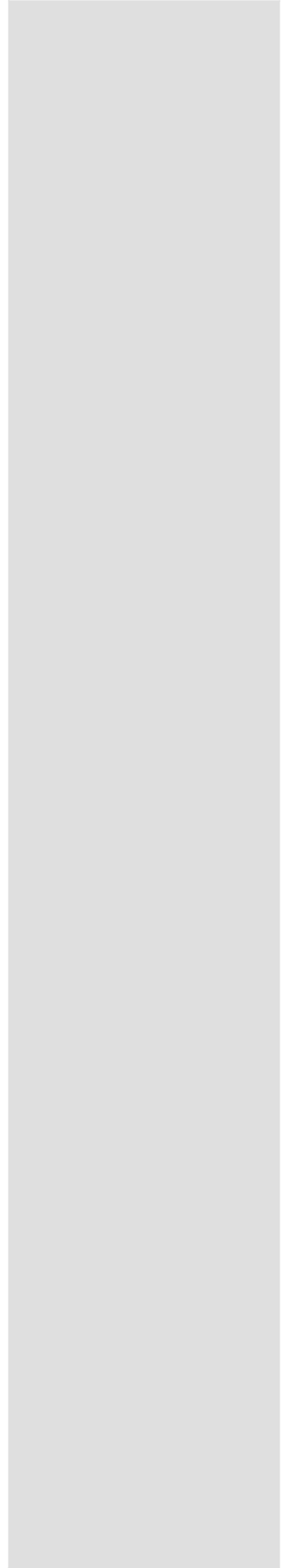

## Dish Antenna Installation

- Loosen both skew bolts and set the skew by rotating the dish mounting bracket to align the red mark with the required angle on the skew scale which you wrote down on page 96. Tighten the skew bolts securely to keep the dish from rotating. Once the skew is set, *do not* try to fine-tune this angle when aiming the dish.

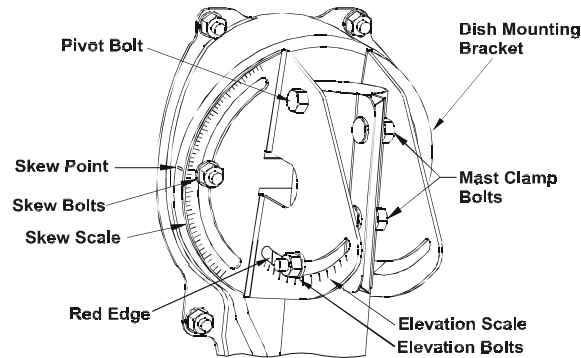

- Set the elevation by tilting the dish mounting bracket to align the red edge with the required angle on the elevation scale. Tighten the elevation bolts, but *do not* tighten the pivot bolt at this time.
- Thread two RG-6 coaxial cables through the mast (optional), support arm and the Y-bracket. These cables should be long enough to run from your receiver to your LNB.



Tighten all the coaxial cable connections *only* by hand. Using a wrench may over-tighten the connections, causing damage. Such damage is *not* covered by the Limited warranty.

**Note:** Since you are installing an all-DISH Pro system, you can have as much as 200 feet of cable between the LNB and the receiver so long as you use only RG-6 coaxial cables *rated for 950 to 2150 MHz*. Some cables may say “Swept tested for 2150 MHz.” If you have any doubt about this, ask your DISH retailer, or look on the container the cable came in. Do not use cable company TV cables or cables from other satellite TV systems not rated for 950-2150 MHz. These other cables may cause signal loss. Do not use existing cables such as RG-59. Also, be sure that any outdoor connections are made using waterproof “F-connectors.”

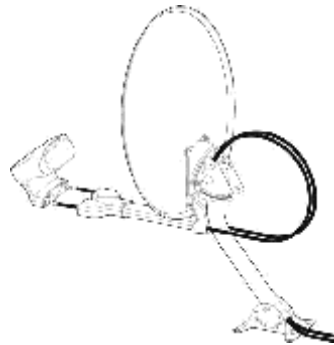

8. Attach the Y-bracket, using the Y-bracket screw.
9. Connect the two RG-6 cables from the DISH Pro Twin LNBF directly to the **Satellite In 1** and **Satellite In 2** connections on the back of the receiver. Be sure there are no multi-dish switches between the LNBF and the receiver. Peel off the blue stickers and affix them to the cables close to where they connect to the **Satellite In 1** and **Satellite In 2** on the back of the receiver.

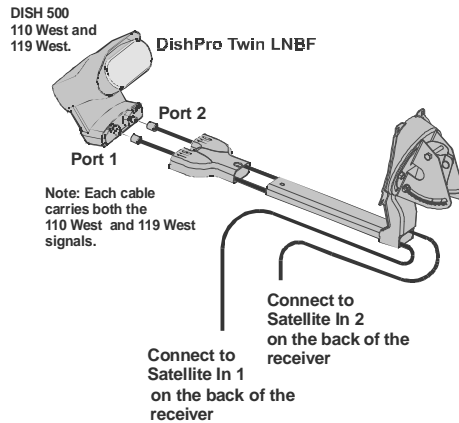

10. Attach the LNBF to the Y-bracket, using the two LNBF screws.
11. Slide the dish assembly down onto the mast. Make sure the pivot bolt rests on the top of the mast. Turn the dish assembly so that it points in the general direction of the satellites, using the azimuth angle from page 96.
12. Make sure both the receiver and your TV is on. You should see the **Point Dish** menu. If not, press MENU on the remote and select **System Setup**, then **Point Dish** or press MENU 6-2 on the remote.

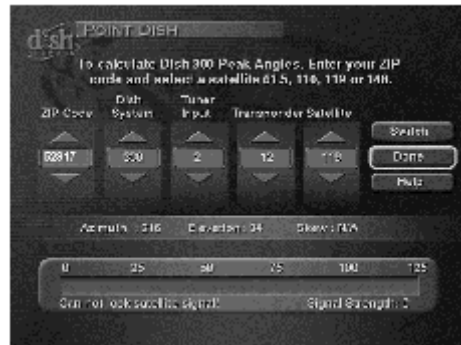

13. Select **Switch**. The **Switch Matrix** screen will open.
14. Select **Check**. The receiver shows you a progress bar and a processing graphic.
15. When the check switch procedure finishes, you should see the following information:

In the **Satellite** line, you will see Xs for both the **Satellite In 1** and **Satellite In 2** tuners. You will also see **Switch Type: No Switch** for both tuners. This is okay and does not mean there is anything wrong with your receiver. You should also see **Twin** next to **Device type** for both tuners. If your **Installation Summary** screen matches this, you can go directly to step #16. If not, do one of the following:

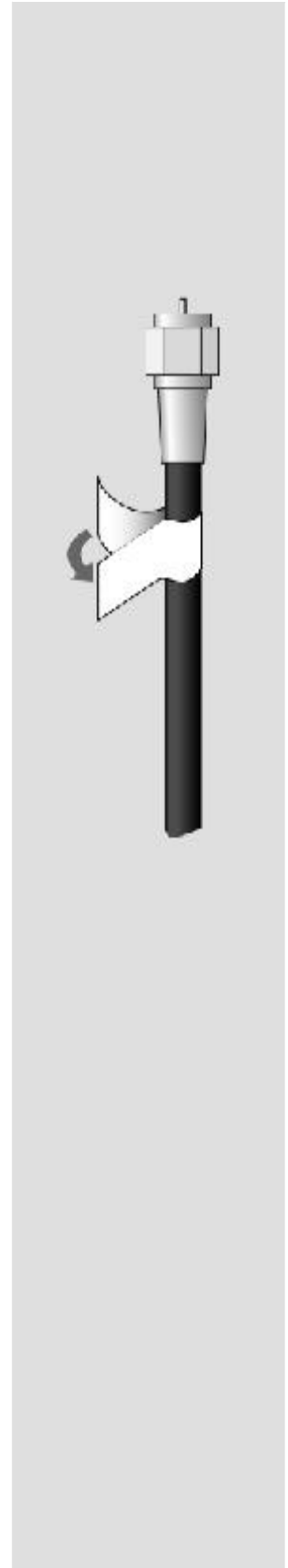

## Dish Antenna Installation

- If, by chance, you happened to pick up a satellite at this point, you may see “110” or “119” in the Satellite line. If “119” shows under **Port 1**, then go to step #16. If “119” shows under **Port 2**, move the dish about 9 degrees to the east, and then select **Check** to run **Check Switch** again. If “110” shows under **Port 2**, then go to Step #16.
  - If “110” shows under **Port 1**, move your dish about 9 degrees to the west, and then select **Switch** to run **Check Switch** again.
16. Select **Done** to return to the **Point Dish** screen. Make sure the check mark is next to **119**. If not, use the UP and DOWN ARROW buttons to select **119**.
  17. Use the signal strength bar to aim the dish or have one person aim the dish while another watches the signal strength or listens to the signal tone. Don't stand in front of the dish while you aim it, because your body will block the satellite signal. After you adjust the aim, let go of the dish so that it can settle back in place by itself. **Do not change the skew setting.**
  18. Turn the dish back and forth *very slowly*, until the signal strength bar turns *green*. This shows you've found the signal.

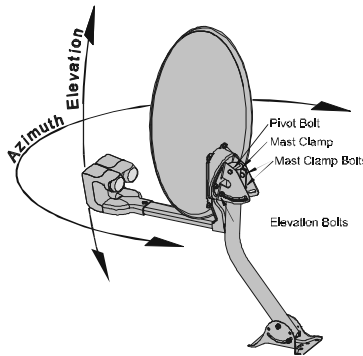

- Note:** If you cannot find the signal, turn the dish back to the first azimuth angle. Then, loosen both elevation bolts *just enough* so you can tilt the dish. Tilt the dish up by two degrees, and then tighten both bolts. Now, turn the dish back and forth again. *If you still can't find the signal*, tilt the dish up again *very slightly* and turn the dish back and forth until you find the signal.
19. Once the signal strength bar is *green*, turn the dish back and forth *just a little*, to where the signal strength bar shows the strongest signal. When you find the strongest signal, tighten both mast clamp bolts. Then loosen both elevation bolts, *just enough* so you can tilt the dish. Tilt the dish up and down *just a little*, to where the signal strength bar shows the strongest signal. **Do not adjust the skew.** When you find the strongest signal, tighten all bolts in the dish assembly so the dish cannot be moved.
  20. You are now ready to verify reception from both satellites. Select **Switch**. When the **Switch Matrix** screen opens, select **Check**. The receiver shows a progress bar and a “Processing” indicator. When the procedure is finished, you will see the **Switch Matrix** screen again.

This time, you *must* see that you have signals from both the **110** and **119** Satellites *for both* **Satellite In 1** and **Satellite In 2**, and the message “Satellite reception verified” for both satellite inputs. Select **Done** to exit this menu.

If you do not see “110,” under **Port 2**:

- Check to make sure the skew angle you wrote down on page 96 is exactly the same as the skew angle you set in step #5 on page 98. If it is not, reset the skew angle as described on page 98. Following this, go back to page 99, and start over from step #12.

21. Look at the **Point Dish** menu. If you have good signal strength with the **119**, use the UP and DOWN ARROW buttons to select **110**. If you have good signal strength on **110**, go to step #22. If you do not have good signal strength with **110**, repeat step #18, and fine-tune the dish with **110** instead of **119**. While the **110** and **119** signals will not be equal, you should be able to fine-tune the dish until you have the strongest possible signal from both satellites. When you have finished this, select **Check Switch**. When the **Check Switch** menu opens, select **Check** to run **Check Switch** again.
22. Select **Done** to exit the **Point Dish** menu.
23. The receiver will begin taking a software upgrade in the background. You will be able to watch TV while this software upgrade is being downloaded from the satellite. However, you will be able to use only the **Browse Banner**, **Program Banner** and UP/DOWN/LEFT/RIGHT ARROWS to find programs to watch during this time.  
**Note:** If you would like to see how the upgrade is progressing, press Menu and select **System Setup** and then **Software Update** or press MENU-6-7.
24. After about an hour, you will see a message regarding the upgrade. When this upgrade finishes, you will be able to watch TV. If you will be installing a multi-dish system, follow the instructions that begin below. If you are installing a system with more than one receiver, you can turn to the *DISH Pro Wiring Diagrams* that begin on page 103 for more information.

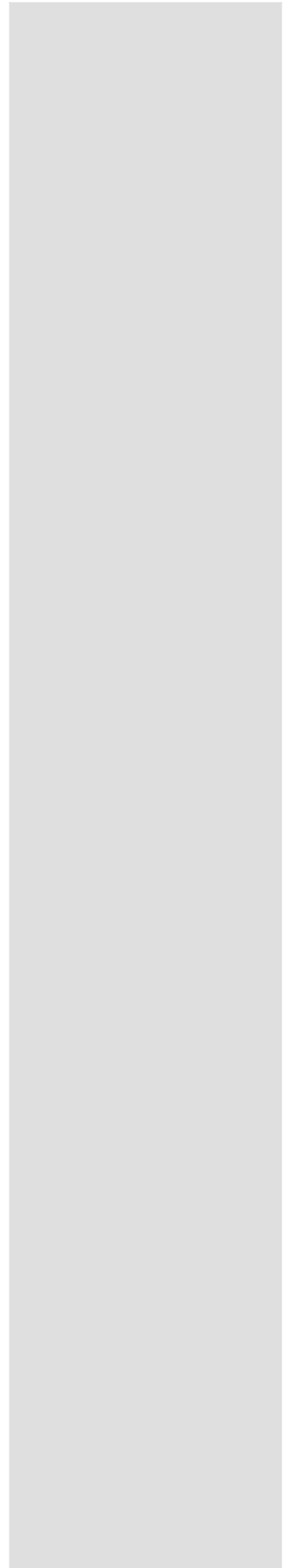

## Installing a Multiple Dish DISH Pro System

---

**Important:** You cannot use DISH Pro LNBFs and switches (those marked with the DISH Pro logo) together with Legacy switches and LNBFs (those without the DISH Pro logo). You must install your DISH antenna system with either all DISH Pro LNBFs and switches or all Legacy LNBFs and switches. *If you mix the two, the system will not work.*

**Note:** Since you are installing an all-DISH Pro system, you can have as much as 200 feet of cable between the LNBF and the receiver so long as you use only RG-6 coaxial cables *rated for 950 to 2150 MHz*. Some cables may say “Swept tested for 2150 MHz.” If you have any doubt about this, ask your DISH retailer, or look on the container the cable came in. Do not use cable company TV cables or cables from other satellite TV systems not rated for 950-2150 MHz. These other cables may cause signal loss. Do not use existing cables such as RG-59. Also, be sure that any outdoor connections are made using waterproof “F-connectors.”

Once you have installed the DISH 500 with DISH Pro LNBFs (using the preceding instructions), you can now install a DISH 300 with a single DISH Pro LNBF as follows:

1. Turn on the television and the receiver if they are not already on. You should see the **Point Dish** screen. If not, press MENU on the remote and select **System Setup** and then **Point Dish**, or press MENU-6-2 on the remote.
2. Use the UP and DOWN ARROWS on the remote to select the correct satellite.
3. Enter your ZIP code to get the necessary azimuth and elevation. Write these down at left.
4. Mount the dish following the mounting instructions that came with it.
5. Connect an RG-6 cable *directly* from the Single DISH Pro LNBF to the **Satellite In 1** port on the DISH Pro receiver’s back panel. Make sure there are no multi-dish switches between the LNBF and the DISH Pro receiver (refer to the wiring diagrams that begin on page 103 for detailed cabling instructions).
6. Point the dish for the strongest possible signal, following the instructions that came with it.
7. Connect any switches in your system, using the instructions that came with the switch(es).
8. Select **Switch** from the **Point Dish** menu. When the **Check Switch** screen opens, select **Check**. When the procedure completes, you will see the **Switch Matrix** screen again. This time you should see that the switch(es) in your system have been correctly identified, and that both **Satellite In 1** and **Satellite In 2** show “Satellite reception verified.”
9. Select **Done** to exit this menu, and then **Done** to exit the **Point Dish/Signal** screen.
10. If there are other receivers in your system, make sure you run **Check Switch** on all of them.

## DISH Pro Wiring Diagrams

---

### DISH 500 with a DISH Pro Twin LNBF, One DISH Pro Single LNBF, One DP34 Switch, Up to Four Receiver Tuners (All DISH Pro)



This diagram leaves out grounding to be clear. Make sure you ground the system per the *National Electrical Code* (NEC) and all local electrical codes.

**Note:** A DISH Network satellite receiver can have either one or two tuners, depending on the model.

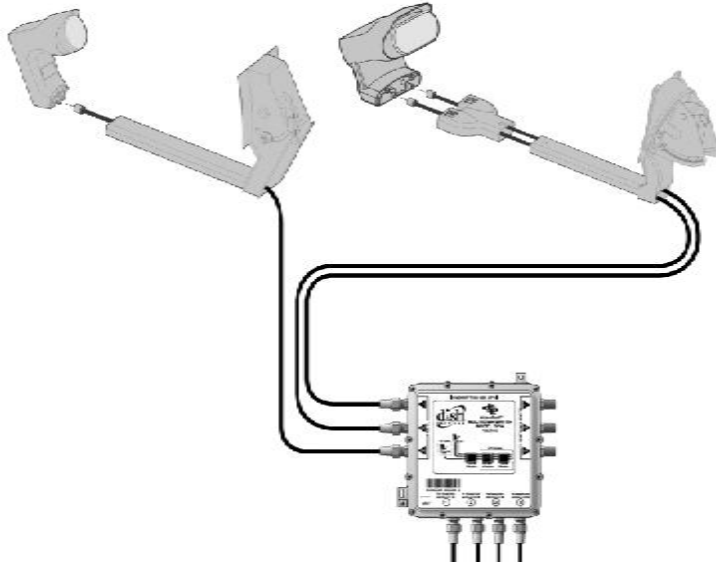

To four DISH Pro  
Receivers or two DISH  
Pro Plus Receivers

**Note:** You can add more receivers to your system by using DP34 Switches as shown above.



## Dish Antenna Installation

### Two Dishes, Three Single-Output DISH Pro Single LNBs, Three Cables, One DP44 Switch, Up to Four Receiver Tuners (All DISH Pro)



This diagram leaves out grounding to be clear. Make sure you ground the system per the *National Electrical Code (NEC)* and all local electrical codes.

**Note:** A DISH Network satellite receiver can have either one or two tuners, depending on the model.

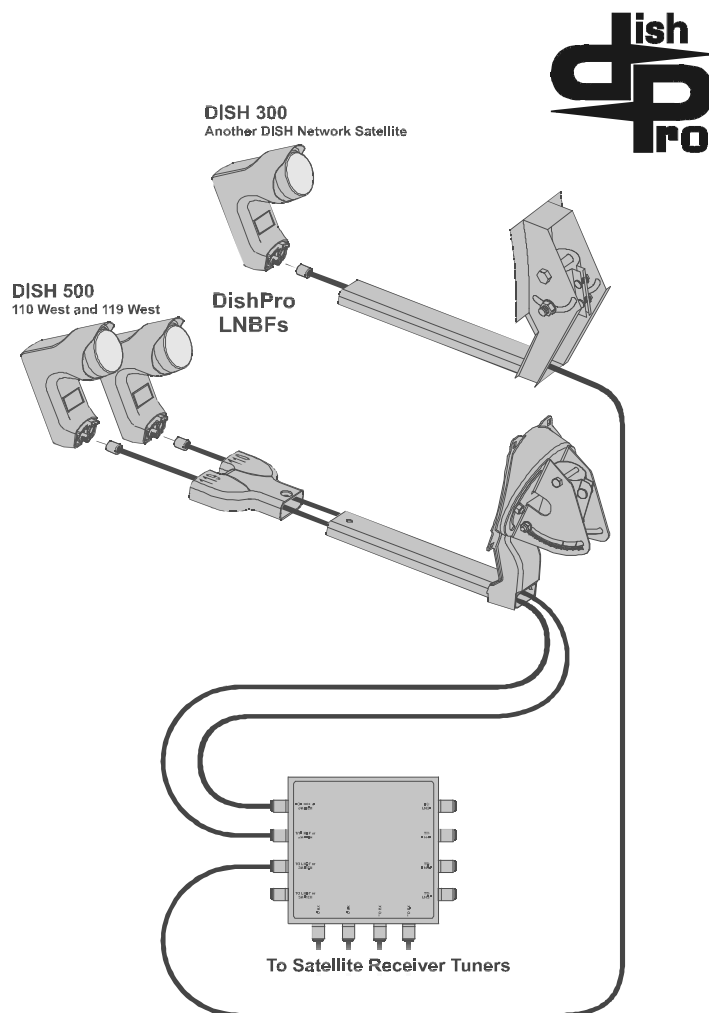

**Note:** You can add more receivers to your system by using DP44 Switches as shown above.

**Three Dishes, Four Single-Output DISH Pro Single LNBs, Four Cables, One DP44 Switch, Up to Four Receiver Tuners (All DISH Pro)**



This diagram leaves out grounding to be clear. Make sure you ground the system per the *National Electrical Code* (NEC) and all local electrical codes.

**Note:** A DISH Network satellite receiver can have either one or two tuners, depending on the model.

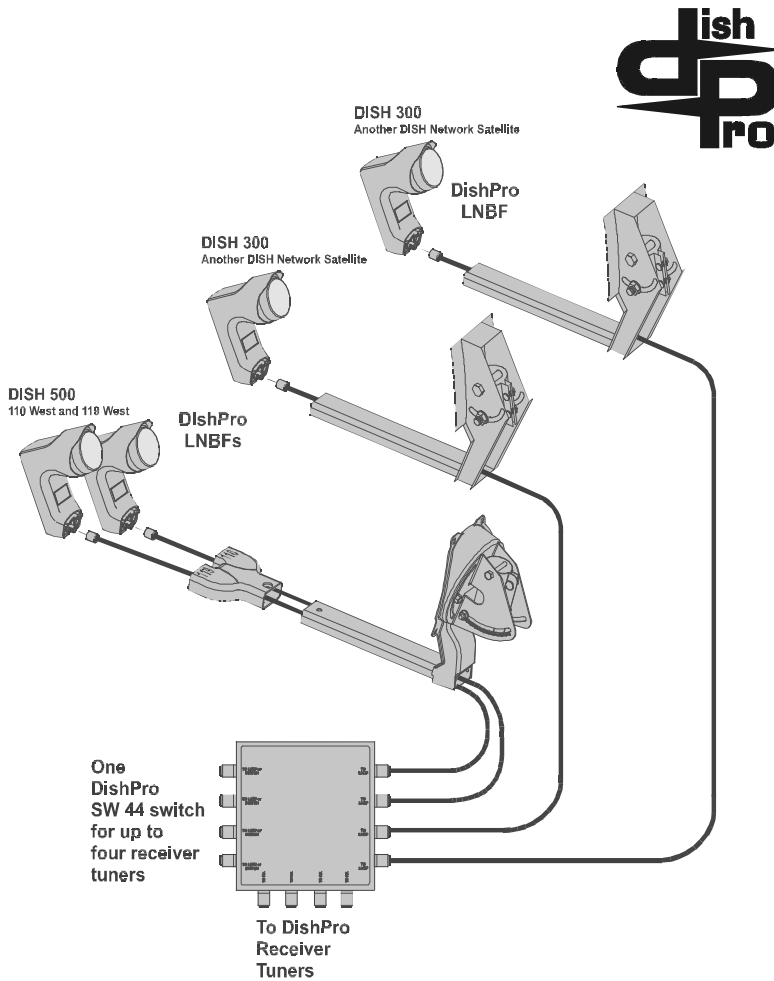

## Dish Antenna Installation

**Two Dishes, One DISH Pro Twin LNBF, One DISH Pro Dual LNBF, Two DISH Pro 21 Switches, Two Receivers. Supports two tuners from three satellite locations.**



This diagram leaves out grounding to be clear. Make sure you ground the system per the *National Electrical Code* (NEC) and all local electrical codes.

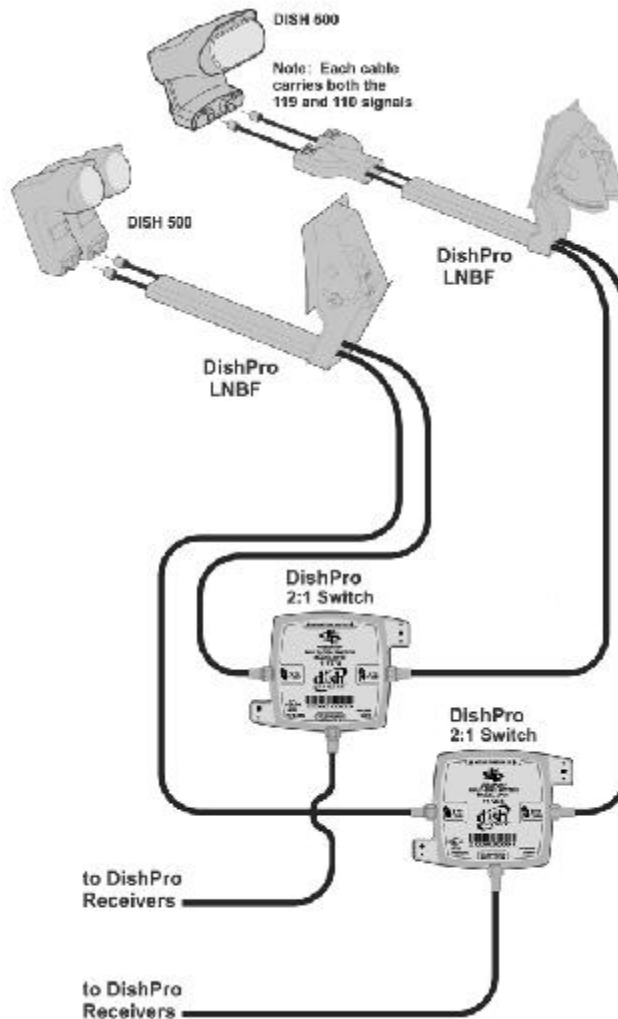

**Note:** When using DP21 switches, make sure that the wiring configuration to each switch is the same. In the diagram above, both switches are connected identically to the LNBFs (Port 1 is connected to a DISH Pro Dual LNBF and Port 2 is connected to a DISH Pro Twin LNBF).

**Two Dishes, Two DISH Pro Dual LNBFs, Two DISH Pro 2:1 Switches, Two Tuners. Supports two tuners from two satellite locations.**



This diagram leaves out grounding to be clear. Make sure you ground the system per the *National Electrical Code* (NEC) and all local electrical codes.

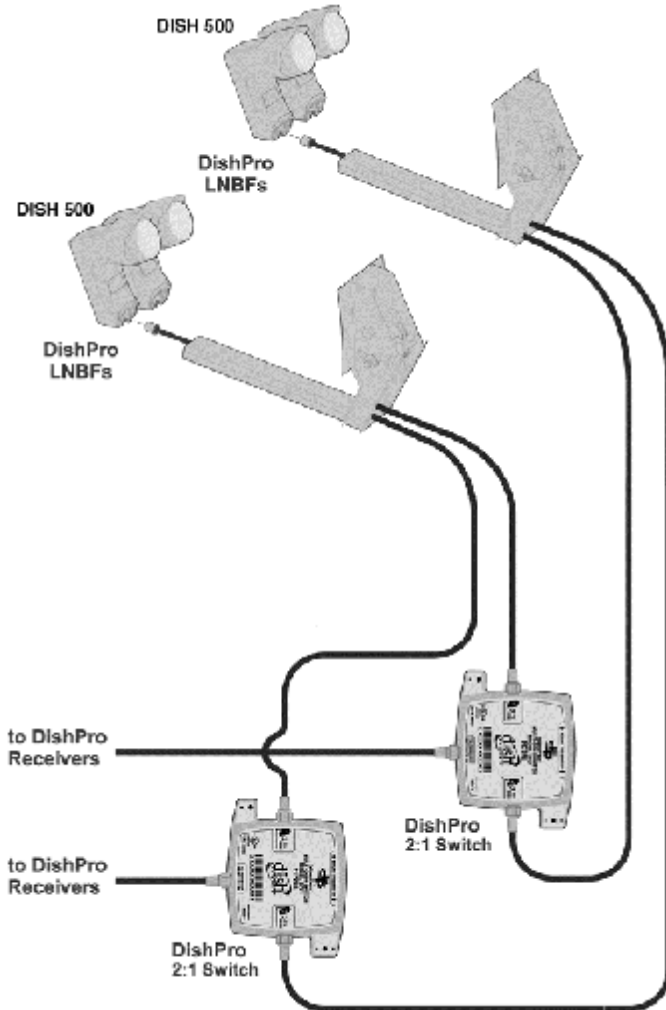

**Note:** When using DP21 switches, make sure that the wiring configuration to each switch is the same. In the diagram above, both switches are connected identically to the LNBFs (Port 1 and 2 are connected to a DISH Pro Dual LNBF).



*Dish Antenna Installation*

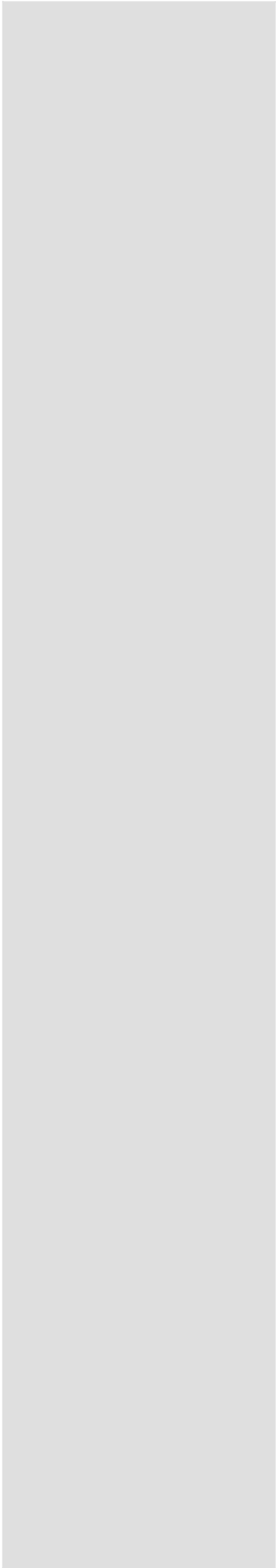

**Notes**

